

FTC STARTER KIT GUIDE

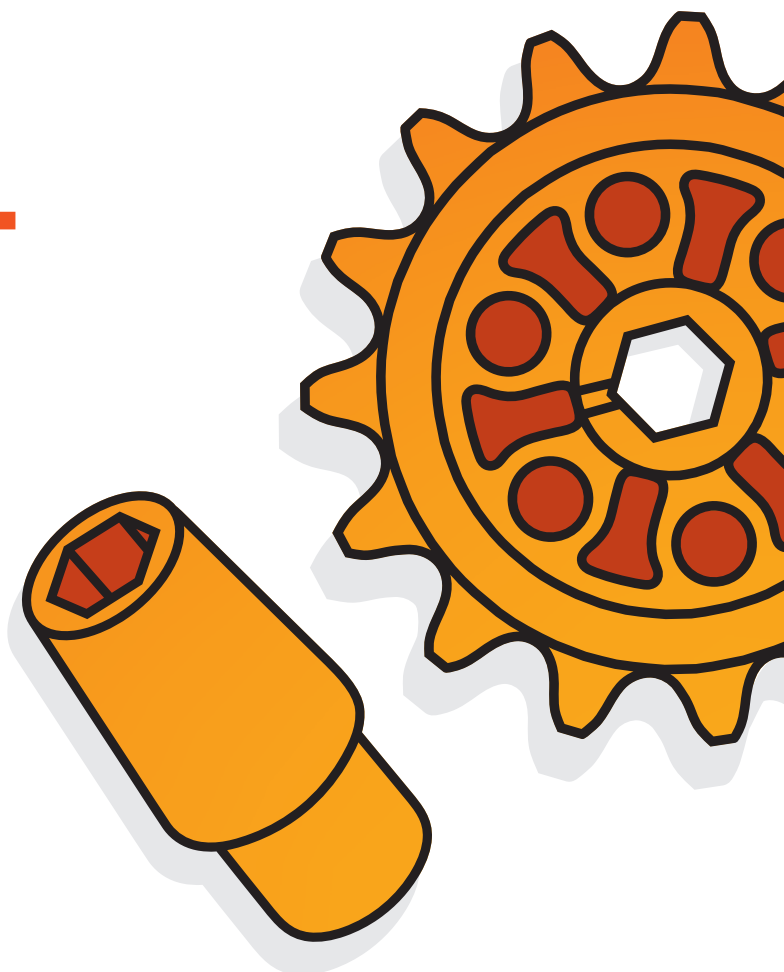

Table of Contents

Welcome Letter	1
Categories of Robot Parts	3
Structure	4-6
Extrusion and C Channel	4
15mm Extrusion	5
15mm x 45mm C Channel	5
Brackets	6
Corrugated Plastic Sheets	6
Hardware and Tools	7
Tips and Tricks for Building	8-10
Actuators	11
Transmitting and Transforming Motion	12-15
Sprockets and Chain	13-14
Gears	14-15
Supporting Motion	16
Constraining Motion	17
Sensors	18
Control System	19-20
Control Hub	19-20
Drivetrain Types	21
Next Steps	22

Version 1.1
Published 2020
Copyright, REV Robotics LLC ©
All trademarks and copyrights are the property
of their respective holders.

REV Robotics
1621 W Crosby Rd #104,
Carrollton, TX 75006

www.revrobotics.com

Sales, Inquires, and POs

sales@revrobotics.com

Help with Products

support@revrobotics.com

Product Distribution

wholesale@revrobotics.com

All other Questions

contact@revrobotics.com

Phone

(844) 255-2267

WELCOME!

Welcome to the *FIRST*[®] community, and thank you for choosing the REV FTC Starter Kit! You are joining a great group of people all working to promote and become the next generation of STEM professionals. Here at REV Robotics, a majority of our staff are *FIRST* Alumni and have been personally involved in STEM Education and *FIRST* for several years.

We founded REV in 2014 to bring new, innovative products to the educational robotics community and to promote the next generation of STEM professionals. When designing products for teams, these experiences are at the forefront of our minds. REV Robotics is always working to create products that help more teams innovate, compete, and achieve their goals.

This guide aims to introduce you to some of the parts in your REV FTC Starter Kit, and serve as a great starting point as you begin to build your robot. For more information or technical assistance, visit our website at www.revrobotics.com or reach out to us via email at support@revrobotics.com

Good luck this season and see you at the competition,
Greg Needel and David Yanoshak
Co-Founders of REV Robotics

Categories of Robot Parts

A robot is built from many varying types of parts. All the parts on a robot can be broken down into the following categories. This guide will explain each category as well as provide some suggestions for building.

Structure

These parts are the framework to which all other robot parts are attached.

Hardware and Tools

Hardware refers to the screws and nuts used to hold the structure together. All the tools needed to work with this hardware and assemble a robot are included in this kit.

Actuators

Actuators, like motors and servos, create motion on the robot.

Transmitting and Transforming Motion

Gears, Chain, and Sprockets are used to transfer motion on the robot. Differences in size of Gears and Sprockets allow for changes in speed and torque.

Supporting and Constraining Motion

Parts such as shaft collars and spacers help restrict or constrain motion to only the intended direction. Unwanted motion hurts the accuracy and repeatability of the robot's actions.

Sensors

Sensors allow the robot and operator to collect information about the surrounding environment. This information allows for better decision making in code.

Control System

These are the parts that control the robot, allowing it to be driven. While Control System parts are not included in this kit they are necessary for a working robot.

Structure

This section goes over all the structure included in the FTC Starter Kit. There is a comparison between Extrusion and C Channel, as well as a few tips and tricks to building with the REV system. The entire REV 15mm Building System is designed to work with standard M3 hardware. This minimizes the number of different sized tools and hardware needed to build a robot.

The major structural elements included in the kit are:

- Extrusion and C Channel
 - 15mm Extrusion
 - 15mm x 45mm C Channel
- Brackets - Attach parts of the robot to each other
- Corrugated Plastic Sheets - Can be cut into any shape needed

Extrusion and C Channel

There are two primary types of structure pieces in the kit, 15mm Extrusion and 15mm x 45mm C Channel. While both have a few similar features, they each have applications best suited for them:

Extrusion	C Channel
<ul style="list-style-type: none">• Slots allow for brackets to be placed anywhere• Adjust design with ease• Smaller profile and less weight than channel• Good for arms, lifts, manipulators, linear motion, and mechanisms• Accepts standard M3 hex head screws	<ul style="list-style-type: none">• Extended Motion Pattern:<ul style="list-style-type: none">- Fixed pattern of mounting holes- Locations for mounting structure, gears, sprockets, bearings, shafts, motors, and servos are available every 16mm• Heavier and more rigid than Extrusion• Good for a robot drivetrain• Accepts standard M3 hex head screws

15mm Extrusion

The flexibility of 15mm Extrusion makes using it a great option for arms, lifts, and other robot manipulators and mechanisms.

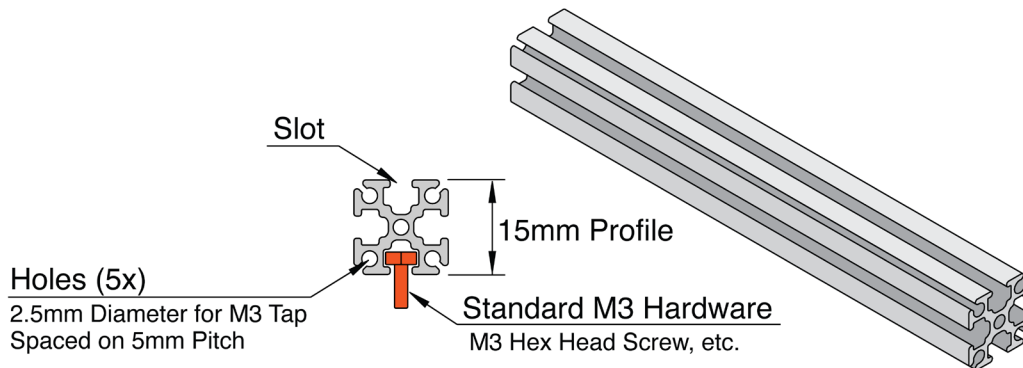

The diagram below shows how slots make it easy to swap, adjust, and iterate as needed.

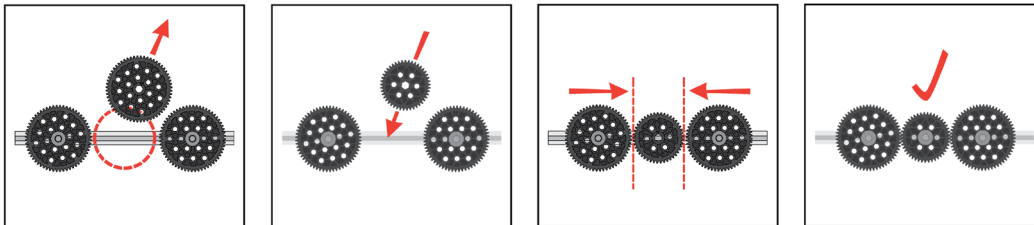

15mm x 45mm C Channel

Using REV C Channel to build a sturdy robot drivetrain is a great start to a robot. The slots on the top of the C Channel allow brackets to connect Channel to Extrusion making it easy to incrementally add on to the robot.

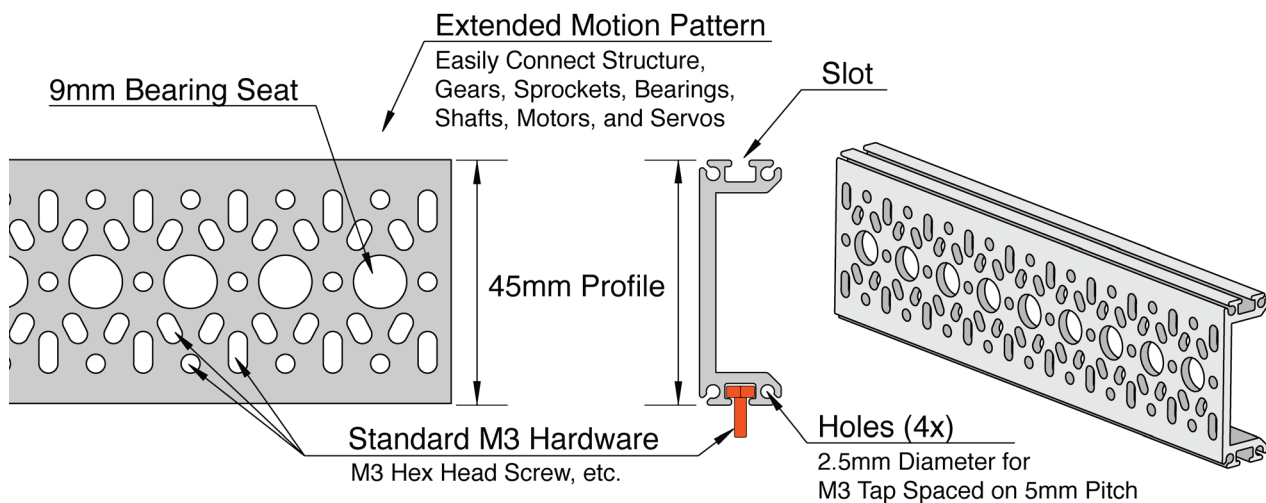

The 45mm wide side of the Channel features the Extended Motion Pattern which allows the use of M3 hardware for attaching structure, gears, sprockets, bearings, shafts, motors, and servos.

Brackets

Brackets are used to join different parts of the robot together. Each REV bracket has features that make them compatible with the other structural parts. The Motion Bracket pictured below is a great example of most of the REV bracket features.

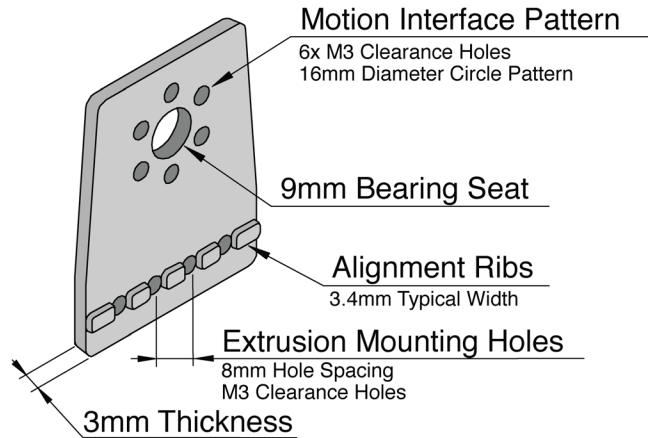

Bracket Features:

- Motion Interface Pattern
 - Circular M3 hole pattern on a 16mm diameter.
 - Used to mount REV Robotics shaft accessories and motors.
- 9mm Bearing Seat
 - For holding any of the plastic bearings used to support a shaft.
- Alignment Ribs
 - Located on one side of the bracket.
 - Ribs help align the bracket to the extrusion slot as well as adding strength and rigidity to joints.
- Extrusion Mounting Holes
 - M3 mounting holes are on an 8mm pitch spacing.

Corrugated Plastic Sheets

Corrugated Plastic Sheets are included in this kit. These are intended for use as a consumable flat stock to make wedges, panels, and more. This plastic is sturdy, lightweight, and easy to cut with hand tools.

Additional types of structural items are available on our website:

- 15mm x 30mm Extrusion (REV-41-1093) offers additional strength while maintaining the flexibility of options the Extrusion slots offer.
- 45mm U Channel (REV-41-1740) can be used in locations where torsional strength is required.
- Various Metal Brackets for situations where additional strength is needed
- *Visit our website to see all additional options*

Hardware and Tools

The REV build system uses M3 hardware to connect, or fasten, brackets and structure together on a robot. Included in this kit are two different lengths of M3 Hex Head Screws and locking M3 Nyloc Nuts. Different applications require different length screws. When attaching a bracket to extrusion, shorter screws are generally required. Use longer screws to connect Control System components and other thicker materials.

Another type of hardware included in the kit is the T-Slot screw. These screws have a T-shaped head allowing them to drop in the slots of the Extrusion or C Channel. This allows for modification of an existing design by adding in brackets and structure without needing access to the end of a slot. Even though T-Slot Screws are convenient, it is always recommended to use full Hex Head Screws because they are a stronger fastener.

See the “Tips and Tricks” section of this guide for best practices when working with the M3 Hardware.

We include all the tools needed to use the parts in the kit. Take a moment to identify the tools below:

- 5.5mm Nut Driver
- 5.5mm Combination Wrench
- Allen Wrench Pack (1.5mm, 2mm, and 2.5mm Allen Wrenches)
- #25 Chain Tool

As robots become more complex, there are additional tools, hardware, and fasteners available on our website:

- 5.5mm Ratcheting Combination Wrench (REV-49-1711)
- 5mm Hex Broach (REV-41-1367) for making hex-shaped holes
- Metric Step Drill (REV-49-1455) for drilling holes of different sizes
- Zip Ties (REV-41-1161)
- Hook and Loop Fastener (REV-41-1373)
- Variety of replacement screws, and additional screw lengths

Tips and Tricks for Building

Take a look at the following tips and tricks so that you can quickly become a master builder with the REV FTC Starter Kit.

Snug, Not Stuck!

When tightening a screw, firm will do. Do not keep tightening until the screw can no longer turn because this can damage structure and actuators. Simply secure the screw to the point that the pressure is firm.

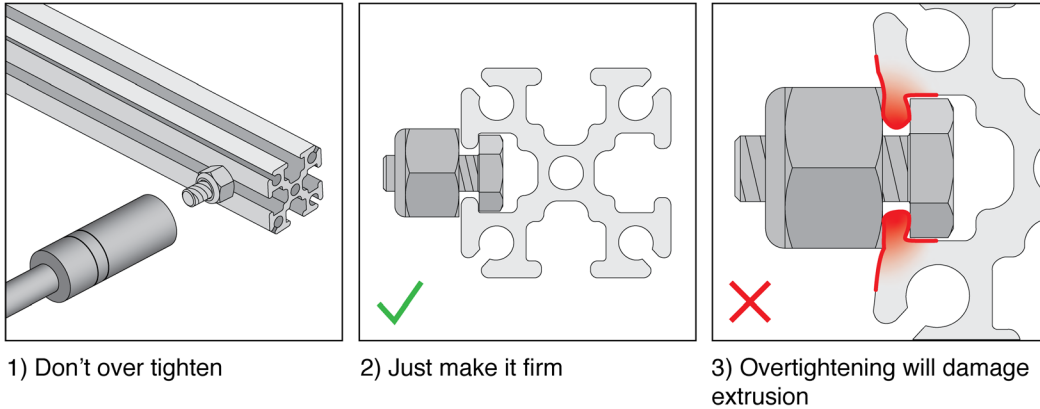

Bracket Ribs Should Face the Extrusion Slot.

The side with the small ribs will always face towards the extrusion when assembling, so that the ribs can help square the bracket to the extrusion.

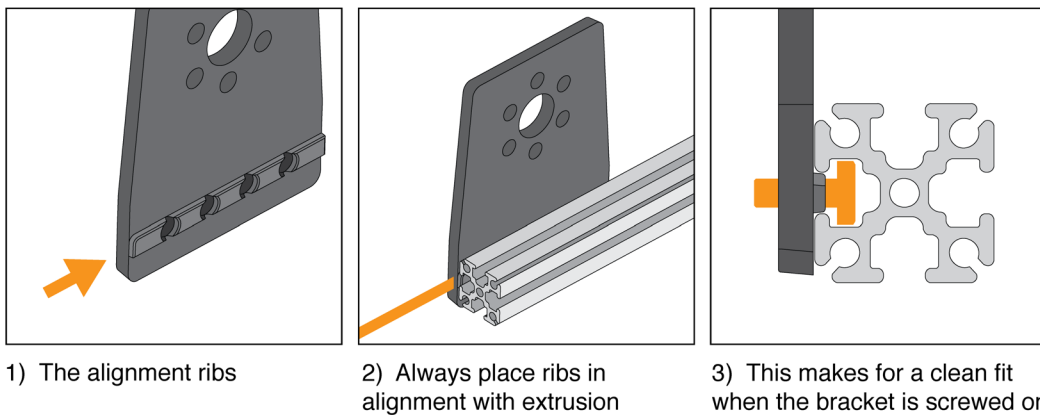

Pre-Load Brackets With Screws

When securing a bracket to extrusion it is recommended to pre-load the bracket with screws. Therefore, the screws are loaded on the bracket before it is even brought near the extrusion. The bracket can then be slid into place along the slot.

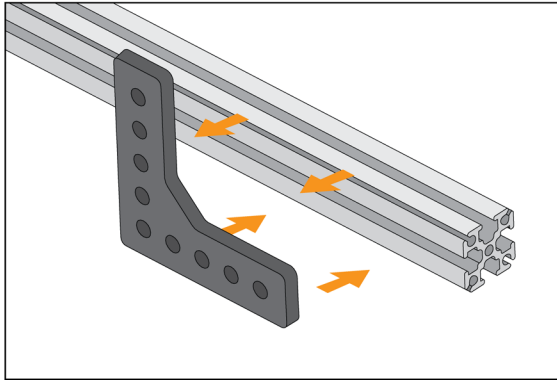

1) Make sure you know which side of your item will be facing the extrusion.

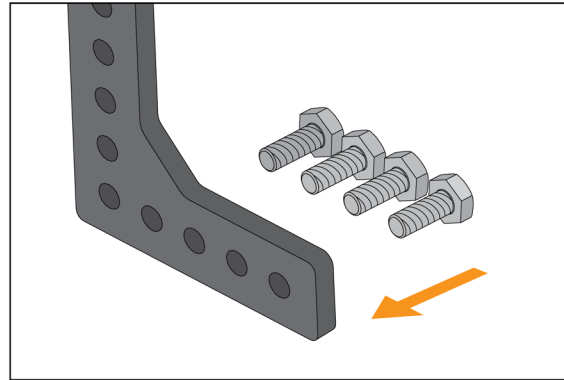

2) Thread the screws onto your piece with the screw heads on the extrusion facing side.

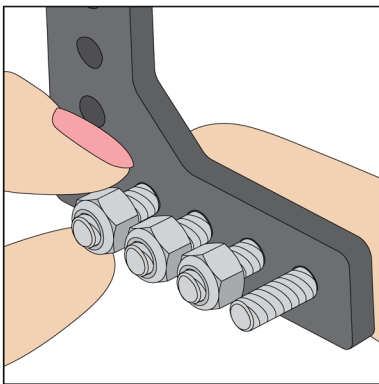

3) Just barely "finger start" the nuts onto the backs of the screws. It should be loose.

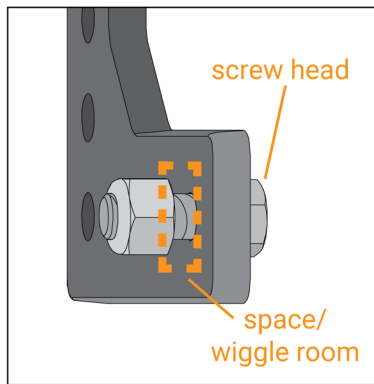

4) Do NOT thread all the way. Just enough so that the nut hangs on to the end.

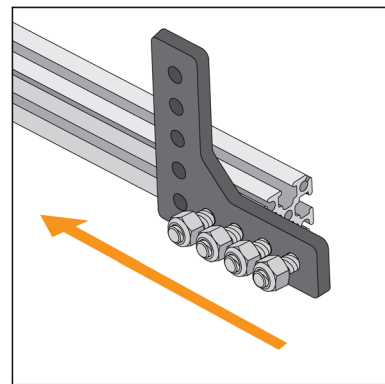

5) Thread the screw heads of your piece onto the extrusion. Slight wiggling will help the screws line up.

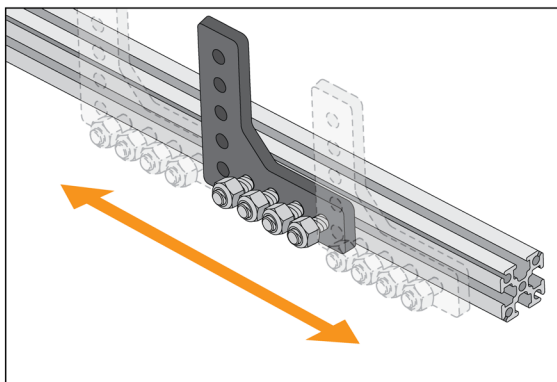

6) You can now slide along the extrusion.

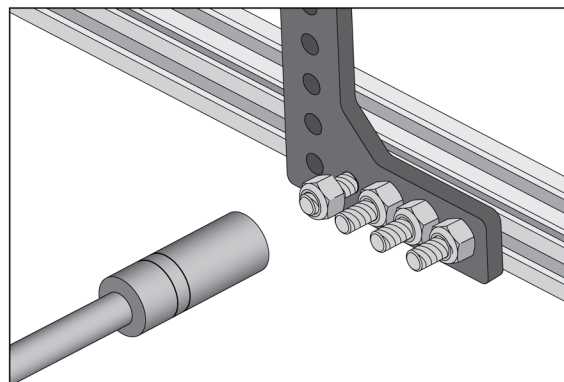

7) Once piece is placed, tighten the screws.

Studs Should Be Up

Building “stud up” is recommended with the REV Robotics System. This means building with the screw head inside of the extrusion. Pay attention to the direction that screws go into the brackets, only the screw head will fit in the extrusion.

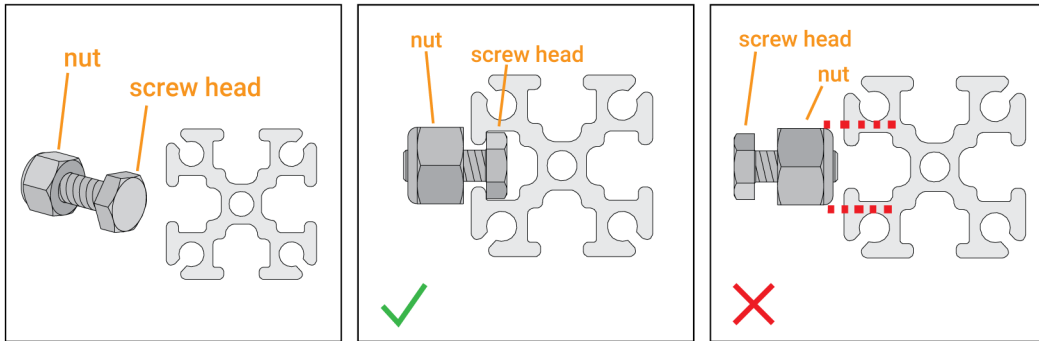

1) When threading a screw and nyloc nut onto extrusion

2) Always thread the screw head in

3) DO NOT try to thread the nyloc nut in. It will not fit.

Nut Direction Matters

When using the nyloc nuts, make sure the beveled “nyloc” side is facing out.

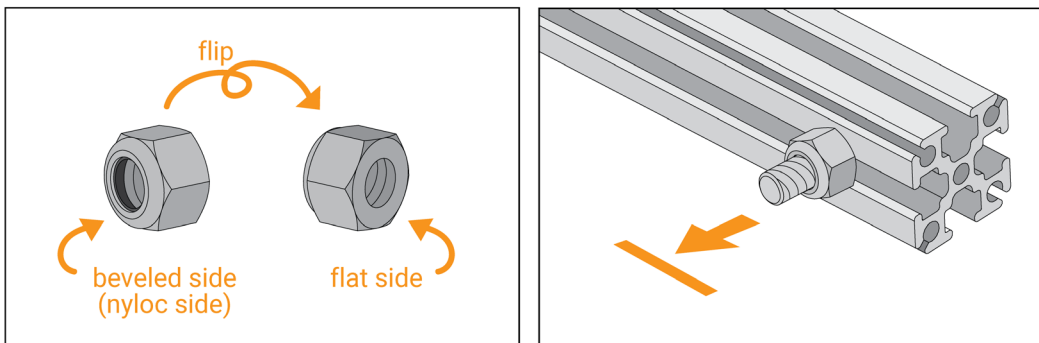

1) Each side of the nut is different

2) Always make sure the beveled side is facing out

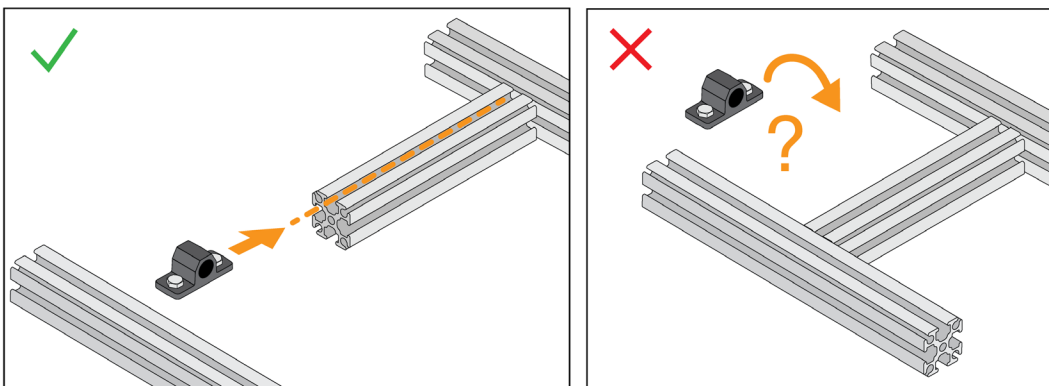

Plan Ahead!

Have a plan for where the brackets and other structure pieces will go before building. Once pieces of extrusion are connected together it can be difficult to go back and add things without having to disassemble the robot.



Actuators

Actuators are devices used to create movement on the robot, such as motors and servos. This section highlights the differences between the REV Motors and Servo included in this kit, as well as their intended uses.

Actuator	Description	Typical Use
<p>HD Hex Motor REV-41-1291</p> 	<p>When the HD Hex Motor is paired with the UltraPlanetary Gearbox, it gives designers control over their end gear ratio, along with two mounting options. Has a built-in encoder.</p>	<p>Drivetrains, Elevators, Arms</p>
<p>Core Hex Motor REV-41-1300</p> 	<p>Features a 90° orientation and a female output shaft for maximum flexibility and ease of use. Has a built-in encoder.</p>	<p>Lighter duty Arms and Intakes</p>
<p>Smart Robot Servo REV-41-1097</p> 	<p>Usable out of the box as a standard angular servo. Configure its angular limits or change it to a continuous rotation servo using the included SRS Programmer. Instructions found at www.revrobotics.com</p>	<p>Lighter duty Intakes, Switches, and Latches</p>

When designing a robot, selecting the correct actuator for the application is important. To find additional details that may help in decision making, please see the ‘Motor Guide’ on our website under ‘Technical Resources.’

Transmitting and Transforming Motion

Transmitting Motion is the act of getting motion from one part of the robot to another using shafts, sprockets, gears, etc.

Transforming Motion is the act of changing the turning force (torque) and speed. Torque and speed are inverse to each other, meaning when one increases the other decreases.

The core to transmitting motion in the REV Build System, is the 5mm hex (hexagonal, six sided) shape. This hex shape is incorporated into the other main motion components, such as: sprockets, gears, wheels, and shafts. Shafts are available in a number of different lengths up to 400mm.

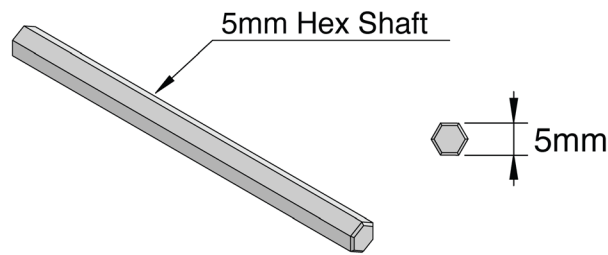

The two primary systems used to transmit motion in this kit are sprockets and gears.

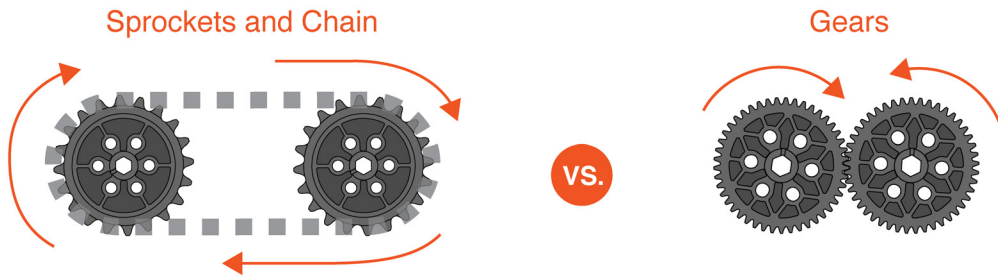

Sprockets and Chain	Gears
<ul style="list-style-type: none"> • Better for transmitting motion over long distances • Changing sprocket sizes requires changing the chain length. • Chain is more forgiving in construction accuracy • Chain tension and wrap are important 	<ul style="list-style-type: none"> • Can be used for changing rotation direction • More compact • More flexibility in adjusting speed and torque • Gear spacing is important

Sprockets and Chain

Sprockets and chain are ideal for transmitting motion over long distances. A chain consists of a continuous set of links that ride on the sprockets to transmit motion. The REV building system is designed around #25 chain using compatible #25 sprockets. The diagram below details the anatomy of a chain.

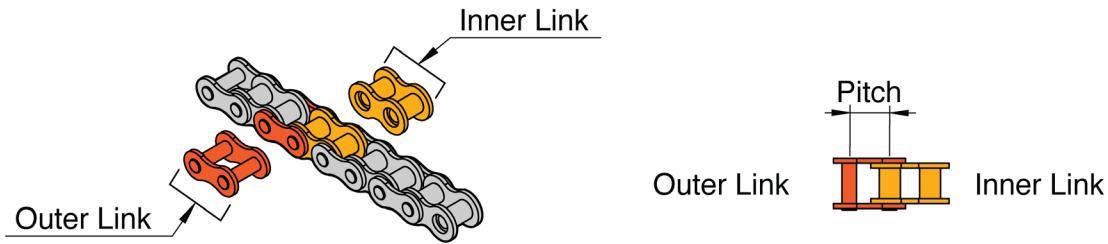

It is important to have proper chain tension when using sprockets and chain. The loop of chain must be the correct length to maintain this tension.

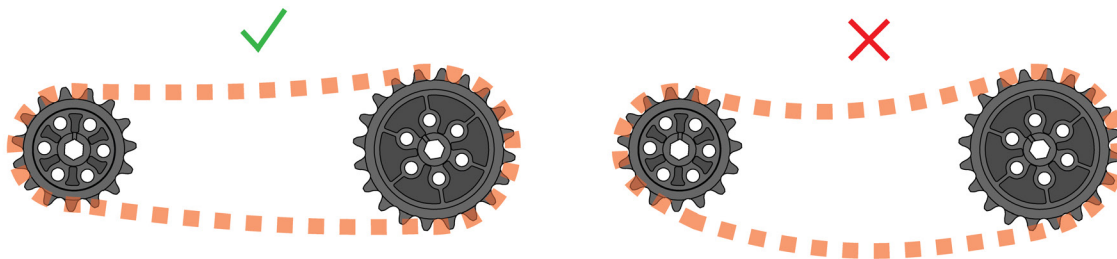

Creating a loop of chain requires breaking off the correct number of links and joining the ends together. Chain can be broken using the Chain Tool and joined using the Master Links included in this kit. The diagram below shows how a Master Link is assembled to replace an outer link.

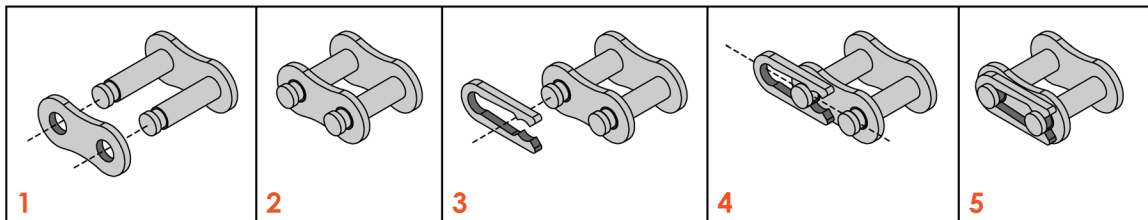

Instead of using a Master Link, the Chain Tool can be used for a stronger, but more difficult joining method. For instructions on how to break and reassemble chain see the 'Chain Tool User's Manual' and 'How-To' video found on its product page on our website.

Transforming the torque and speed of the motion is accomplished by changing the size of the sprockets.

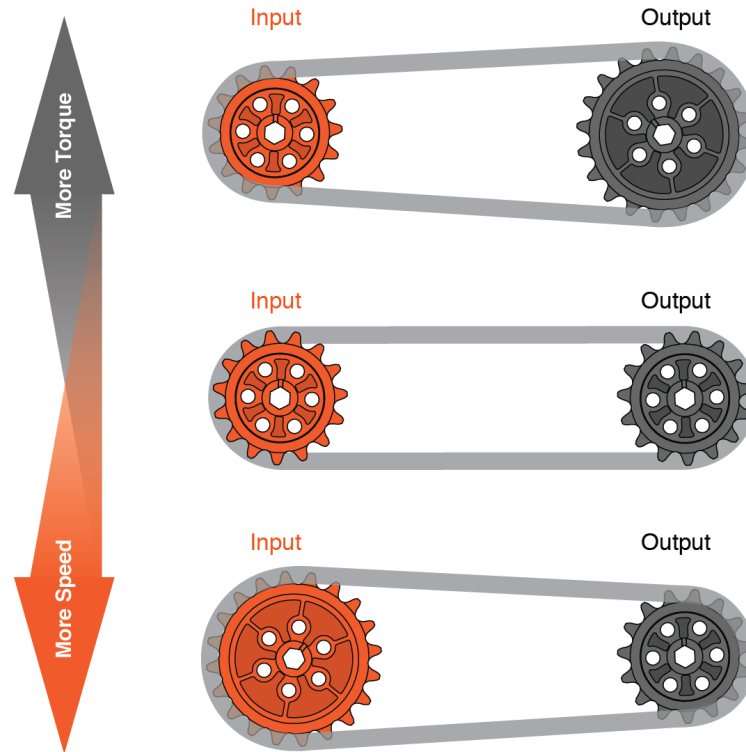

Gears

Gears have teeth that must be meshed with other gears in order to transmit motion. They are ideal for use in more compact spaces and are better for changing the direction of rotation. The speed and torque of the motion can be transformed by using different sized gears. Gears offer more flexibility in transforming motion than sprockets and chain because there are a larger variety of gear sizes available.

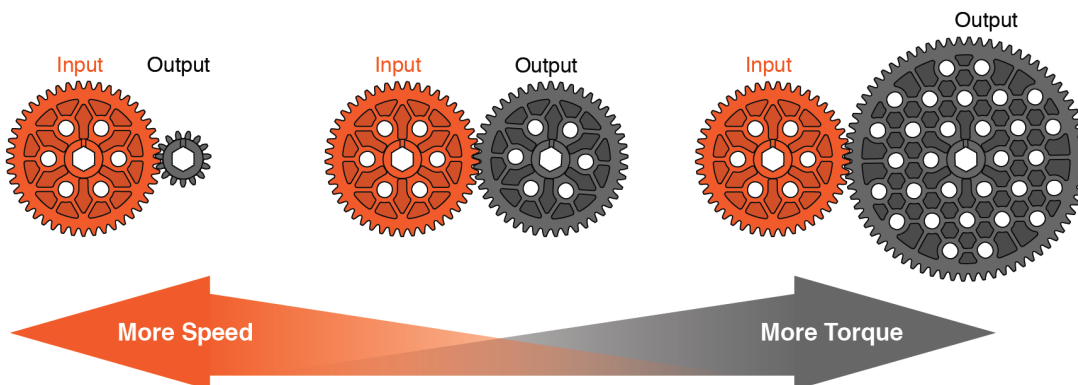

Another compact gearing system included in the kit is the UltraPlanetary Gearbox Kit. The UltraPlanetary system consists of pre-assembled and lubricated gear cartridges, one of each 3:1, 4:1, and 5:1 gear ratio. Easily adjust torque and speed for different applications by configuring different combinations of cartridges.

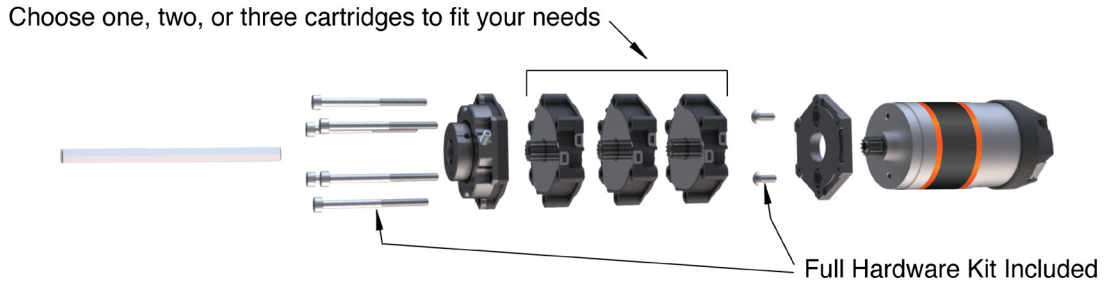

A wide range of gear ratios are possible with the three included cartridges. When combining up to three cartridges, just multiply each cartridge gear ratio to find the overall gear ratio. For example, a combination of the 4:1 and 5:1 cartridges would make a 20:1 overall gear ratio. The table below shows the common use cases for all possible ratios that can be created with the included UltraPlanetary kit.

	1 Cartridge			2 Cartridges			3 Cartridges
	3:1	4:1	5:1	12:1	15:1	20:1	60:1
Drivetrains	x	x	x	Speed		Balanced	Pushing
Mechanisms	Fast Intakes, Flywheels			Intakes, Conveyors			Arms



While this table is a good starting point, please take a look at the UltraPlanetary Gearbox Kit User's Manual on our website before configuring the gearbox. The guide contains detailed information about the system features and its limitations that are very useful when designing a robot.

Additional individual UltraPlanetary cartridges are available on our website.

Supporting Motion

Supporting the assemblies that move on the robot is very important. Without planning proper supports, shafts may not be able to spin or actuators could be easily damaged.

Forces, or loads, that are at a right angle to the shaft are the most important forces to counteract. The floor pushing on a wheel or two gears pushing against each other are two examples of these forces. It is best to support a shaft with two supports, one on each end. Without two supports, the shaft can pivot in the direction of the force. If, and only if, two supports are not possible, it is very important to minimize the distance between the force and the single support.

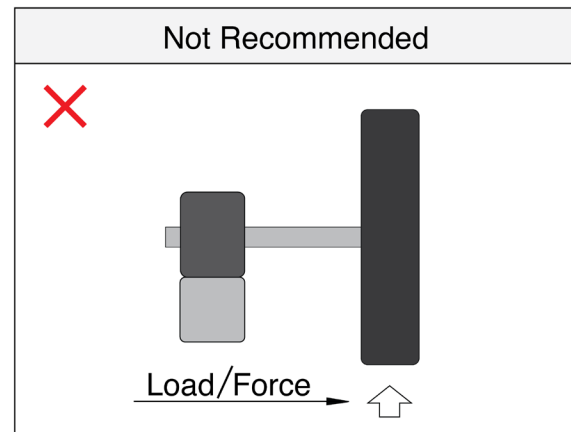
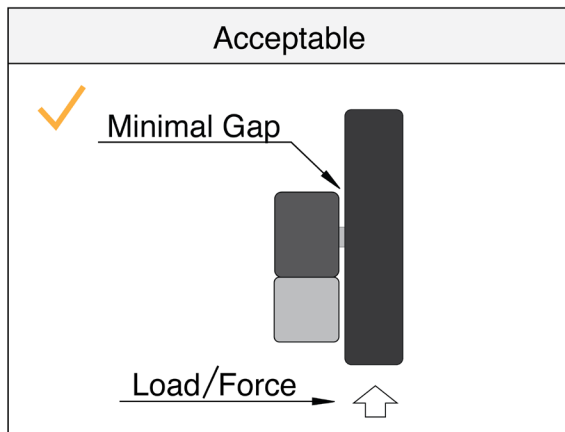
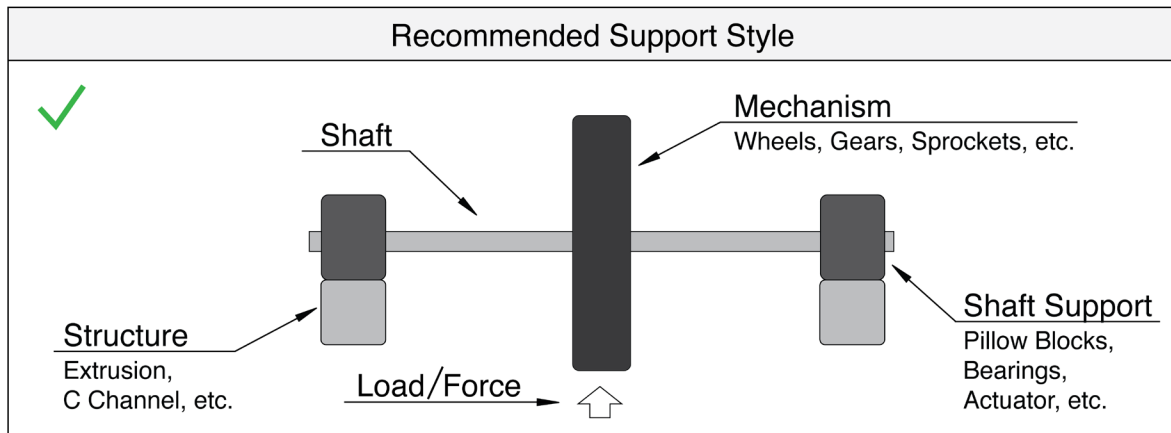

Some products that can be used to support motion assemblies are;

- Bearing Pillow Blocks (REV-41-1317)
- Motion Bracket (REV-41-1303) used in tandem with a bearing
- Bearing Block (REV-41-1317) is recommended for supporting shafts in heavy duty applications

Constraining Motion

Robots need movement to accomplish goals; arms must pivot, wheels must turn, etc. However, movement that isn't directly related to those actions can affect the accuracy and precision of the robot mechanisms. This unintended motion must be properly restricted, or "constrained".

Long and thin structures can flex and deform, making it difficult to interact with objects and operate in a repeatable manner. Make use of brackets and additional Extrusion or C Channel to strengthen and constrain these structures.

Gears and sprockets must stay aligned or else they won't work properly. For example, if two sprockets are not perfectly aligned with each other, the chain between them will run off the sprockets. Keeping parts aligned on a shaft, and keeping the shaft itself from sliding out is critical for reliably working robot mechanisms. Use a combination of spacers and shaft collars to align and constrain these parts into place.



1.5mm Spacers
REV-41-1325



3mm Spacers
REV-41-1324

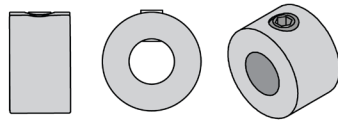

Shaft Collar
REV-41-1330

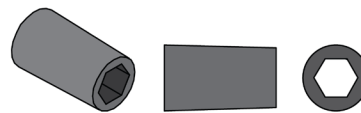

15mm Spacer
REV-41-1323

Sensors

When starting out, many of the robot actions can be accomplished by turning on a motor for a specific amount of time. Eventually, these time-based actions may not be accurate or repeatable enough. Battery power drains over time, mechanisms wear in, wheels pick up dust, all of which affect time-based actions. Fortunately, there is a way to give feedback to the robot about how it is operating by using **Sensors**; devices that are used to collect information about the robot and the environment around it.

All REV Robotics motors contain a built-in sensor called an Encoder. Encoders are used to sense how far and at what speed a motor shaft has spun. Feeding this information back to the robot, and writing code that uses it, allows the robot to drive an accurate distance, rather than for a specific amount of time.

While the built-in motor encoders are the only sensors included in the FTC Starter Kit, there are plenty of other sensors available to give your robot the feedback it needs. The following sensors are categorized based on their sensor interface type and complexity.

Digital Sensors (Basic)

Magnetic Limit Switch (REV-31-1462)

- Detects the presence of magnets
- Two mountable magnets included
- Typically used to limit motion between two points

Touch Sensor (REV-31-1425)

- Detects when its button is pressed
- Typically used as a button or bumper

Analog Sensors (Basic)

Potentiometer (REV-31-1155)

- Senses angular position of a shaft
- Helpful when building simple arm joints

I2C Sensors (Intermediate)

2m Distance Sensor (REV-31-1505)

- Measures distances up to 2 meters with millimeter resolution
- Typically used to measure distance to an opaque object

Color Sensor V3 (REV-31-1557)

- Detects and reports color values
- Also has a built-in Proximity Sensor for short distance measurement

I2C Sensors (Advanced)

Inertial Measurement Unit (IMU)

- Robot orientation sensor
- Built into the Control/Expansion Hub

USB Sensors (Advanced)

USB Webcams

- Used with advanced vision processing code to detect objects

For more information on sensors, such as when and how to use them, see the sensor guide on our website under ‘Technical Resources.’

Control System

While there are no control system components included in this starter kit, a control system is required for a functional robot and many of the components in this kit connect to control system components. This section will explain the necessary parts of a control system, as well as the features of the Control Hub. Teams often reuse the same control system components year after year.

The Control System of a Robot consists of:

- **A Robot Controller** - Where the code is stored and run
 - Two controller options:
 - Control Hub - Described in this guide
 - FTC legal Android device connected to an Expansion Hub
 - Many robot components will connect to Control/Expansion Hub
- **A Driver's Station** - FTC legal Android device
- **A Gamepad** connected to the driver's station - Used to control the movement of the robot

Control Hub

The Control Hub is similar to a brain; decisions are made and actions are taken based on the code stored on it. All actuators and sensors are connected to the Control Hub through the various ports shown below.

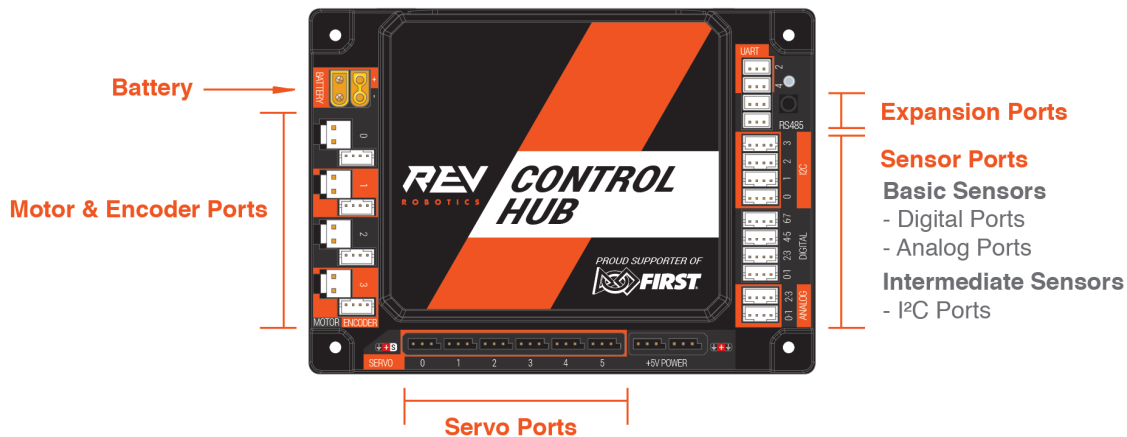

Battery Connection

The power for the entire robot is provided by a 12V battery. This battery is connected to the Control Hub through one of its yellow battery connectors. Additional devices can be daisy-chained off of the second battery connector if needed.

Motor and Encoder Ports

Up to four motors can be connected to the Control Hub through these ports. Each Motor Port has a corresponding Encoder Port where the motor's built-in encoder is also plugged in.

Servo Ports

Up to six servos can be connected to the Control Hub through these ports.

Expansion Ports

These ports, labeled 'RS485' are used to connect an Expansion Hub to the Control Hub, which doubles the amount of available ports.

Sensor Ports

Besides encoders, all other sensors are connected to these ports. Sensors must be connected to the ports matching the sensor's interface type: Digital, Analog, or I²C. Generally, digital and analog sensors are classified at a basic level of complexity compared to the more intermediate level I²C sensors.

Digital Ports

Each of the four basic digital ports have two digital channels, so up to eight digital sensors can be connected to the hub.

Analog Ports

Each of the two basic analog ports have two analog channels, so up to four analog sensors can be connected to the hub.

I²C Ports

There are four separate I²C ports on the hub. I²C sensors are technically digital sensors, but they are more complex and therefore require their own ports.

This is an example of a Control Hub wired to a number of actuators and sensors, as well as the Battery and power switch. This will vary based on how a robot is designed.

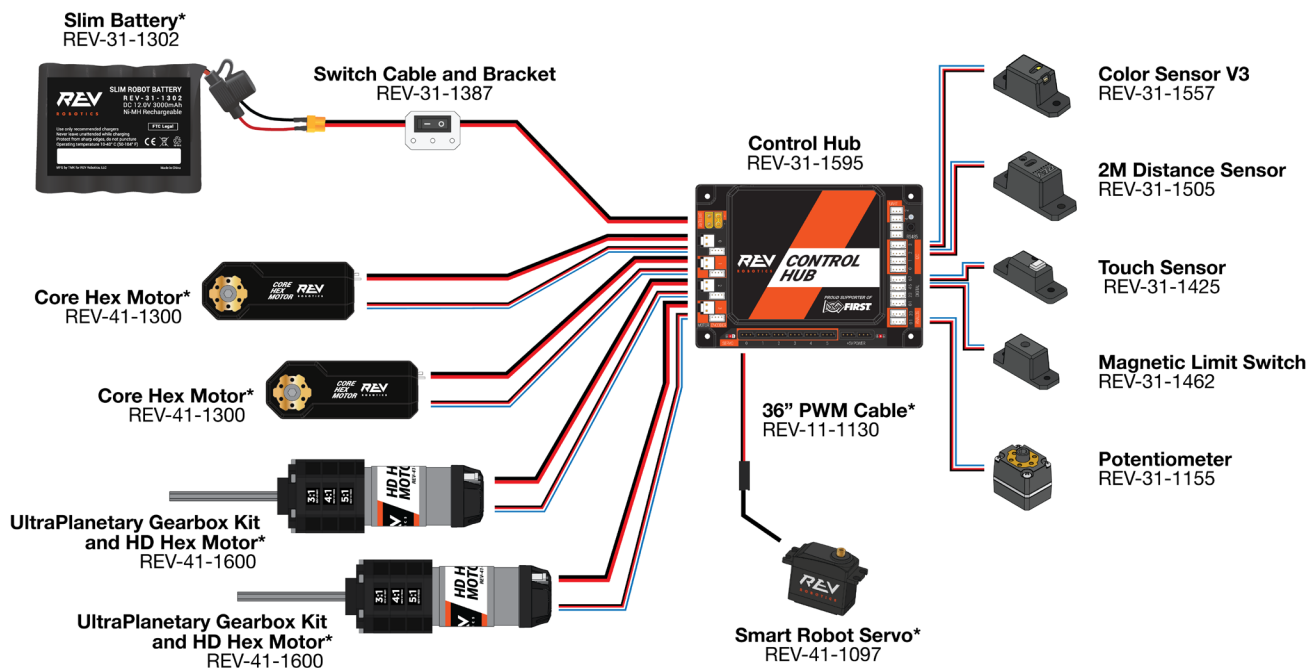

**These items are included in this kit*

For additional information on the Control Hub, please see our 'Control Hub Getting Started Guide' on www.revrobotics.com.

Drivetrain Types

One of the first considerations when designing a robot is identifying what kind of drivetrain will be built. Some drivetrain types to consider building are:

C Channel with Chain Drivetrain and Open Front

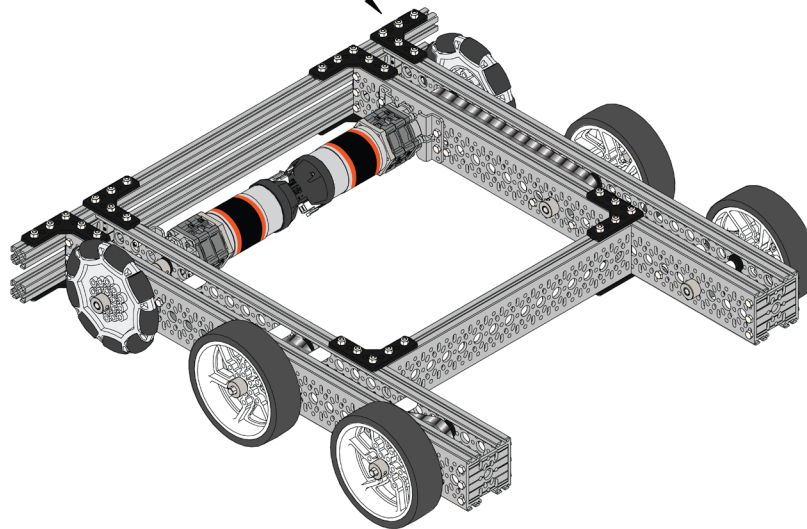

Extrusion with Chain Drivetrain and Closed Front

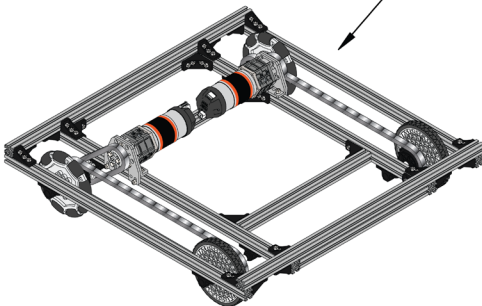

Extrusion with Gear Drivetrain and Closed Front

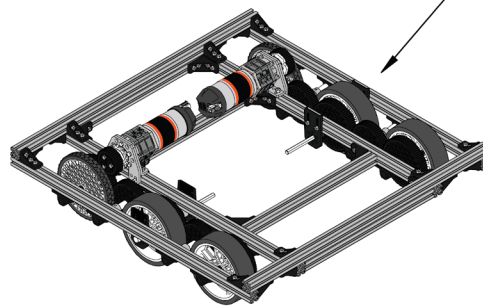

Drivetrain	C Channel with Chain and Open Front <i>(recommended)</i>	Extrusion with Chain and Closed Front	Extrusion with Gears and Closed Front
Ease of Assembly	● ● ● ●	● ● ●	●
Design Flexibility	● ● ● ● ●	● ● ●	● ● ●
Reliability	● ● ● ● ●	● ● ●	● ●
Serviceability	● ● ● ●	● ● ●	● ● ● ●

Step-by-step guides for assembling each drivetrain shown, are available for free on our website.

Next Steps

The REV FTC Starter Kit is a great way to start building a robot that is ready to drive. Depending on what the robot is designed to accomplish, additional parts may be required. Unsure of where to go next? Take a look at the following frequently asked questions for common next steps.

Want more maneuverability?

Our 75MM Mecanum Wheel Set (REV-45-1655) will give your robot the ability to move in all directions, including side to side. Each of the four wheels need their own motor, therefore two additional UltraPlanetary Gearbox Kit & HD Hex Motors (REV-41-1600) are required. Please be aware the additional maneuverability comes with added complexity in design and programming.

Have you run out of motor ports?

One to two extra motors?

The SPARKmini Motor Controller (REV-31-1230) allows you to add additional motors. You will also need a XT30 Power Distribution Block (REV-31-1293) to power the additional motors.

More than two motors?

Consider getting an Expansion Hub (REV-31-1153). The Expansion Hub has the same number of ports as, and connects directly to, the Control Hub.

Need linear motion?

See the Linear Motion section on our website for solutions that are compatible with the REV Building System.

Looking for an alternative to chain?

Timing belts and pulleys are lighter, more compact, and efficient at transferring motion than chain and sprockets. Belts do not stretch over time as much as chain making re-tensioning less of an issue.

Want options to customize the look of your robot?

Check out our 15mm Extrusion Slot Covers (REV-41-1633)! They come in seven colors and are made of flexible PVC that fit directly in the slots of the Extrusion or Channel.

Looking for even more customization?

The Blinkin LED Driver (REV-11-1105) combined with the available LED strips can communicate robot status to the operator and give your robot a unique look.

Need extra or replacement parts?

Replacements for items in the FTC Starter Kit can be found on our website along with all of our other fully compatible components.

Check out the Technical Resources tab on our website!

Individual product guides can be found on each products' page.

Have a technical question?

The best way to get answers is to email us at support@revrobotics.com

